

Clarke®



UNIVERSAL MOBILE BASE

MODEL NO: CUMB1

PART NO: 7630211

ASSEMBLY & OPERATING INSTRUCTIONS

LS0613

INTRODUCTION

Thank you for purchasing this CLARKE Universal Mobile Base.

Before attempting to use this product, please read this manual thoroughly and follow the instructions carefully. In doing so you will ensure the safety of yourself and that of others around you, and you can look forward to your purchase giving you long and satisfactory service.

GUARANTEE

This product is guaranteed against faulty manufacture for a period of 12 months from the date of purchase. Please keep your receipt which will be required as proof of purchase.

This guarantee is invalid if the product is found to have been abused or tampered with in any way, or not used for the purpose for which it was intended.

Faulty goods should be returned to their place of purchase, no product can be returned to us without prior permission.

This guarantee does not effect your statutory rights.

IN THE CARTON

Unpack and identify all components and hardware. Make sure there are no missing parts and that there is no shipping damage.

Qty	Description	Qty	Description
4	Long Side Rails	25	½" Bolt
4	Short Side Rails	25	Small Flange Nut
2	Castor Plate	2	Large Nut
2	Castor Corner Bracket	2	Large Flange Nut
2	Fixed Wheel Corner Bracket	2	2½" Cam Pivot Bolt
2	Cam Lever	6	Self-locking Nut
2	Adjustable Foot	2	Pivot Rod Bolt
2	Castor	2	1¾" Wheel Axle Bolt
2	Wheel		

SAFETY INSTRUCTIONS FOR MOBILE BASES

1. Place the mobile base on a level surface and adjust the feet before placing the machine in position. This should stop the machine rocking, while testing it for stability. Test for stability in both the up (on the castors) and the down positions.
2. Take extra care when testing the stability of top heavy machines.
3. Unplug any power tool before moving or repositioning the mobile base.
4. Always check stability for safety after repositioning.
5. Care should be taken when planning the orientation of the machine on the universal mobile base. When the weight is on the castors the machine will tilt 1/2" toward the fixed wheels.
6. Never use your machine while it is supported on the two swivel castors. Always lower the machine onto the adjustable feet before use.
7. When moving the base, always push the base, not the machine. take care not to tilt the machine over when moving.
8. SECURE ALL FASTENERS - Make sure that all nuts & bolts on the mobile base are fully tightened before use.
9. RATED WEIGHT LIMIT - Do not install machines exceeding the rated weight capacity of the mobile base. (See Page 7)
10. APPROPRIATE LOCATION FOR USE - Use only on flat, smooth, sturdy surfaces, that are free of debris and able to support the weight of the machine and the operator.
11. DISENGAGE CAM LEVERS - Verify that all cam levers are disengaged and the based is being supported on the adjustabler feet before turning on your machine. Failure to ensure that your machine is completely immobile may cause serious injury if the machine begins to move across the floor during use.
12. BEFORE YOU MOVE THE MACHINE - Ensure that there is a clear path to the destination. Avoid rolling over any power cords or debris, clutter or obstructions.
13. DO NOT OVERLOAD - The mobile base is designed to roll smoothly when operating within its rated weight capacity and requires only steady pressure to move around. If you find that excessive force is needed, STOP and check for obstructions or damage to the wheels before proceeding.

ASSEMBLY INSTRUCTIONS

ASSEMBLE THE CASTOR BRACKETS

1. Attach castor plate to the castor bracket using a pivot rod bolt and self locking nut.

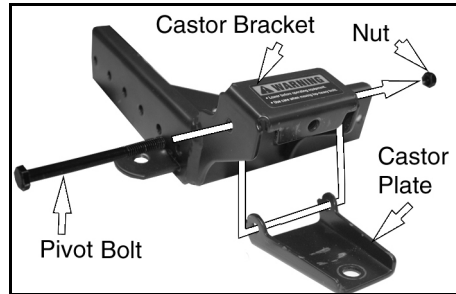

2. Screw the adjustable foot into the threaded hole in the foot bracket.
3. Fit the large nut onto the top of the adjustable foot.

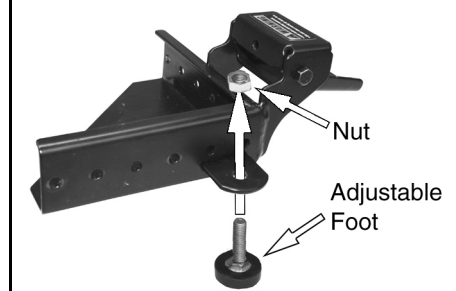

4. Attach the castor to the castor plate using a large flange nut.

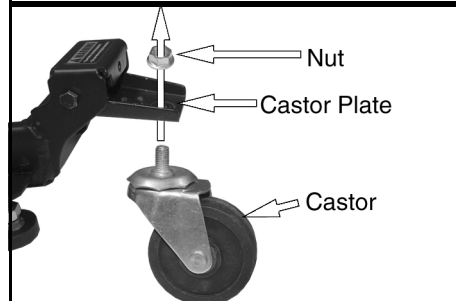

5. Attach the cam lever to the castor bracket using a 2 1/2" cam pivot bolt and self locking nut.

NOTE: Both cam levers should be oriented towards the centre of the base.

6. Follow steps 1-5 again for the second castor bracket assembly.

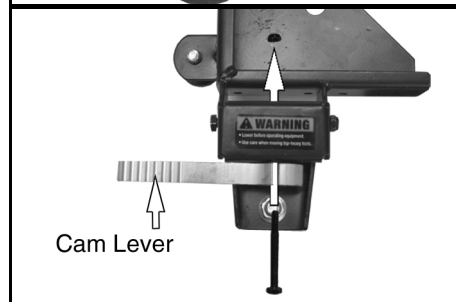

FITTING THE FIXED WHEELS

1. Position the wheel as shown.
2. Insert the 1 $\frac{3}{4}$ " Wheel Axle Bolt through hole in the outer edge of the wheel housing, wheel, and secure to corner using a self locking nut.

NOTE: Use care not to overtighten which would prevent the wheel from turning.

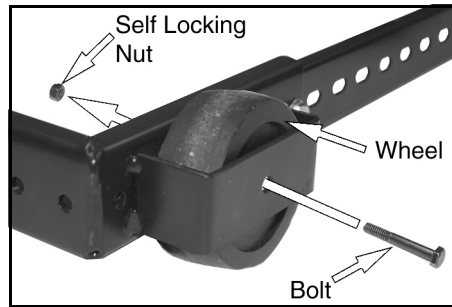

MEASURE THE FOOTPRINT OF YOUR MACHINE

Take note of the outside measurements of your machine and add about 1" to the dimension. (1" allows clearance for the fasteners). Keep in mind the base is adjustable in 1" increments.

NOTE: A table saw is shown in this example for illustration purposes only.

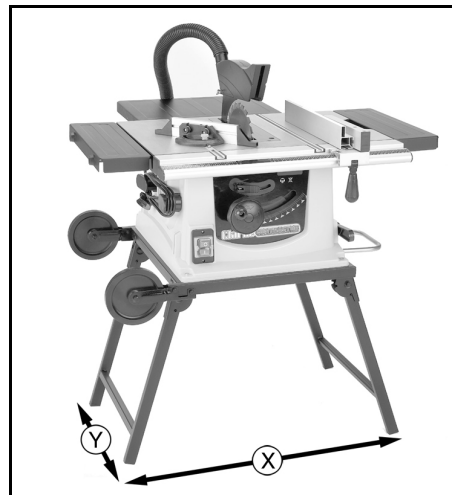

CAUTION: WE RECOMMEND THAT YOU USE THIS MOBILE BASE WITH MACHINES THAT HAVE A LOW CENTRE OF GRAVITY.

CONNECTING THE FOUR CORNERS TOGETHER

1. Select and arrange the corners and side rails to assemble the base the same size as your machines footprint.
2. Bolt the side rails to the corners and to each other using these simple rules:
 - a. All connections require the use of two ½" bolts and two small flange nuts at each end of the connections and if the rails join each other.
 - b. The side rails must be fitted into the corners as far as possible.
 - c. Keep your universal mobile base symmetrical.



NOTE: The nuts should be on the inside of the mobile base.

NOTE: Re-check dimensions, then tighten all bolts and nuts.

LOCKING AND UNLOCKING THE CASTOR WHEELS

1. Move the Cam Lever to the 'castors up' or 'castors down' position shown on the right.
2. When the castors are in the down position the base will tilt slightly, Make sure the any machine being supported does not tip over, especially if it is top heavy.

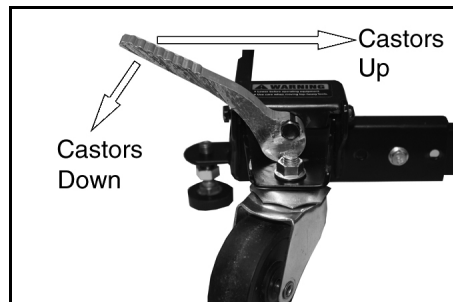

LEVELLING THE BASE

1. With the based raised (the castors locked in the down position), loosen the locking nut on the adjustable feet.
2. Screw the foot in or out of the threaded hole as required, so that it makes contact with the floor when not being supported by the castors.
 - You will need to lower the base and check that the base is level when it is not being supported by the castors.
3. Retighten the locking nut.

PLACING YOUR MACHINE ON THE BASE

1. With assistance, lift the machine to be mobilized onto the mobile base.

ORIENTATION

The feed direction must be at right angle to the orientation of the fixed wheels to prevent the base from moving during machine operation.



GROUND CLEARANCE

This product should only be used on an even floor.



CAUTION: CHECK STABILITY IN BOTH THE UP AND DOWN POSITIONS BEFORE USING. FAILURE TO FOLLOW SAFETY AND ASSEMBLY INSTRUCTIONS MAY RESULT IN PERSONAL INJURY OR DAMAGE TO THE PRODUCT.

SPECIFICATIONS

Model Number	CUMB1
Part Number	7630211
Maximum Weight Loading	230 kg
Minimum Size	304 x 304 mm
Maximum Size (Square)	914 x 914 mm
Maximum Size (Rectangle)	508 x 1320 mm
Product Weight	7 kg

A SELECTION FROM THE VAST RANGE OF

Clarke®

QUALITY PRODUCTS



AIR COMPRESSORS

From DIY to industrial, Plus air tools, spray guns and accessories.

GENERATORS

Prime duty or emergency standby for business, home and leisure.

POWER WASHERS

Hot and cold, electric and engine driven - we have what you need

WELDERS

Mig, Arc, Tig and Spot. From DIY to auto/industrial.

METALWORKING

Drills, grinders and saws for DIY and professional use.

WOODWORKING

Saws, sanders, lathes, mortisers and dust extraction.

HYDRAULICS

Cranes, body repair kits, transmission jacks for all types of workshop use.

WATER PUMPS

Submersible, electric and engine driven for DIY, agriculture and industry.

POWER TOOLS

Angle grinders, cordless drill sets, saws and sanders.

STARTERS/CHARGERS

All sizes for car and commercial use.

PARTS & SERVICE: 020 8988 7400

E-mail: Parts@clarkeinternational.com or Service@clarkeinternational.com

SALES: UK 01992 565333 or Export 00 44 (0)1992 565335

Clarke® INTERNATIONAL Hemnall Street, Epping, Essex CM16 4LG
www.clarkeinternational.com